

Installation & Maintenance Instructions

2-WAY DIRECT-ACTING SOLENOID VALVES
 NORMALLY CLOSED OPERATION — 1/4" NPT
 LIQUID PETROLEUM GAS SERVICE

SERIES
8262H
"Suffix B"
I&M No. V9580

NOTICE: See separate solenoid installation and maintenance instructions for information on: Wiring, Solenoid Temperature, Causes of Improper Operation, Coil or Solenoid Replacement.

DESCRIPTION

Series 8262H valve are 2-way direct-acting solenoid valves designed for Liquid Petroleum Gas (Propane) service. Valve bodies are made of rugged brass. The valve may be provided with a general purpose, explosionproof or explosionproof/watertight solenoid enclosure depending upon requirements.

OPERATION

Normally Closed: Valve is closed when solenoid is de-energized; open when energized.

Note: No minimum operating pressure required.

INSTALLATION

Check nameplate for correct catalog number, pressure, voltage, frequency, and service. Never apply incompatible fluids or exceed pressure rating of the valve. Installation and valve maintenance to be performed by qualified personnel.

Note: Inlet port will either be marked "1" or "IN". Outlet port will be marked "2" or "OUT".

Temperature Limitations

For valve ambient and fluid temperature ranges refer to chart below. Check catalog number, prefix, and watt rating on nameplate to determine temperatures.

Prefix ^①	Coil Class	Watt Ratings		Maximum Ambient Temperature	
		AC		°C	°F
		60 Hz	50 Hz		
EF, EV	FT	10.1	10.1	52	125
EF, EV	FB	17.1	17.1		
	FT	10.1	10.1	55	131
	FB	17.1	17.1		
	HT	10.1	10.1		
	HB	17.1	17.1		
EF, EV	HT	10.1	10.1	60	140
EF, EV	HB	17.1	17.1		

① = EF, EV data applies to Explosionproof coils only.

Valve Elastomer	Coil Class	Watt Ratings		Max Fluid Temperature	
		AC		°C	°F
		60 Hz	50 Hz		
Lt – Nitrile	FT, HT	10.1	10.1	75	167
	FB, HB	17.1	17.1		

Future Service Considerations

Provisions should be made for performing seat leakage, external leakage, and operational tests on the valve with a nonhazardous, noncombustible fluid after disassembly and reassembly.

Positioning

This valve is designed to perform properly when mounted in any position. However, for optimum life and performance, the solenoid should be mounted vertically and upright to reduce the possibility of foreign matter accumulating in the solenoid base sub-assembly area.

Mounting

Two (2) M5 threaded holes are provided in the valve body for mounting. See Figure 1. M5 threads will accept standard 10-32 screw. Optional mounting bracket can be obtained with the valve as Suffix MB or separately as a kit.

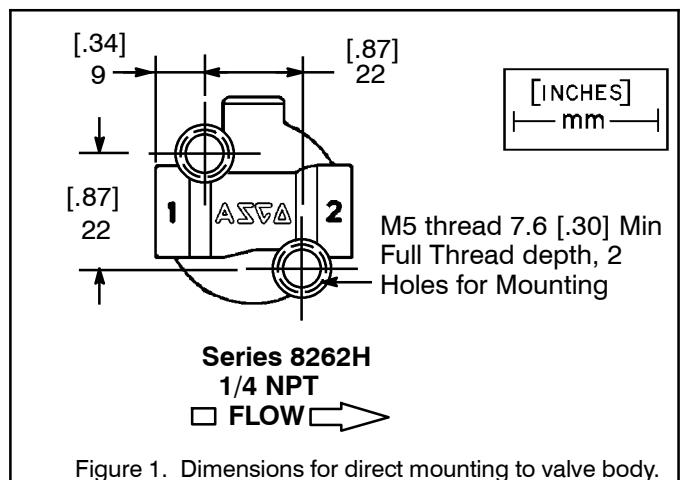

Piping

Connect piping to valve according to markings on valve body. Inlet port will either be marked "1" or "IN". Outlet port will be marked "2" or "OUT". Apply pipe compound sparingly to male pipe threads only. If applied to valve threads, the compound may enter the valve and cause operational difficulty. Avoid pipe strain by properly supporting and aligning piping. When tightening the pipe,

do not use valve or solenoid as a lever. Locate wrenches applied to valve body or piping as close as possible to connection point.

▲ CAUTION: To protect the solenoid valve, install a strainer or filter suitable for the service involved in the inlet side as close to the valve as possible. Clean periodically depending on service conditions. See ASCO Series 8600, 8601 and 8602 for strainers.

MAINTENANCE

▲ WARNING: To prevent the possibility of death, serious injury or property damage, turn off electrical power, depressurize valve, extinguish all open flames and avoid any type of sparking or ignition. Vent hazardous or combustible fluid to a safe area before servicing the valve.

NOTE: It is not necessary to remove the valve from the pipeline for repairs.

Cleaning

All solenoid valves should be cleaned periodically. The time between cleanings will vary depending on the medium and service conditions. In general, if the voltage to the coil is correct, sluggish valve operation, excessive noise or leakage will indicate that cleaning is required. In the extreme case, faulty valve operation will occur and the valve may fail to open or close. Clean strainer or filter when cleaning the valve.

Preventive Maintenance

- Keep the medium flowing through the valve as free from dirt and foreign material as possible.
- While in service, the valve should be operated at least once a month to insure proper opening and closing.
- Depending on the medium and service conditions, periodic inspection of internal valve parts for damage or excessive wear is recommended. Thoroughly clean all parts. If parts are worn or damaged, install a complete ASCO Rebuild Kit.

Causes of Improper Operation

- **Incorrect Pressure:** Check valve pressure. Pressure to valve must be within range specified on nameplate.
- **Excessive Leakage:** Disassemble valve and clean all parts. If parts are worn or damaged, install a complete ASCO Rebuild Kit.

Valve Disassembly (Refer to Figure 2)

1. Disassemble valve in an orderly manner using exploded view for identification of parts.
2. Remove solenoid, see separate instructions.
3. Unscrew solenoid base sub-assembly from valve body. Then remove bonnet gasket and core assembly with core spring and core guide.
4. All parts are now accessible to clean or replace. If parts are worn or damaged, install a complete ASCO Rebuild Kit.

Valve Reassembly

1. Use exploded view for identification, orientation and placement of parts.
2. Lubricate all gaskets with DOW CORNING® 200 Compound lubricant or an equivalent high-grade silicone oil.
3. Install body gasket in valve body.
4. Install core assembly with core spring and core guide into solenoid base sub-assembly.
5. Hand thread solenoid base sub-assembly (with core assembly) into valve body.
6. Torque solenoid base sub-assembly to 175 ± 25 in-lbs [$19,8 \pm 2,8$ Nm].
7. Install solenoid, see separate solenoid instructions. Then make electrical hookup to solenoid.

▲ WARNING: To prevent the possibility of death, personal injury or property damage, check valve for proper operation before returning to service. Also perform internal seat and external leakage tests with a nonhazardous, noncombustible fluid.

8. Restore line pressure and electrical power supply to valve.
9. After maintenance is completed, operate the valve a few times to be sure of proper operation. A metallic *click* signifies the solenoid is operating.

ORDERING INFORMATION FOR ASCO REBUILD KITS

Parts marked with an asterisk (*) in the exploded view are supplied in Rebuild Kits. When Ordering Rebuild Kits for ASCO valves, order the Rebuild Kit number stamped on the valve nameplate. If the number of the kit is not visible, order by indicating the number of kits required, and the Catalog Number and Serial Number of the valve(s) for which they are intended.

